

HAFCO METALMASTER

MILL DRILL OPERATION MANUAL

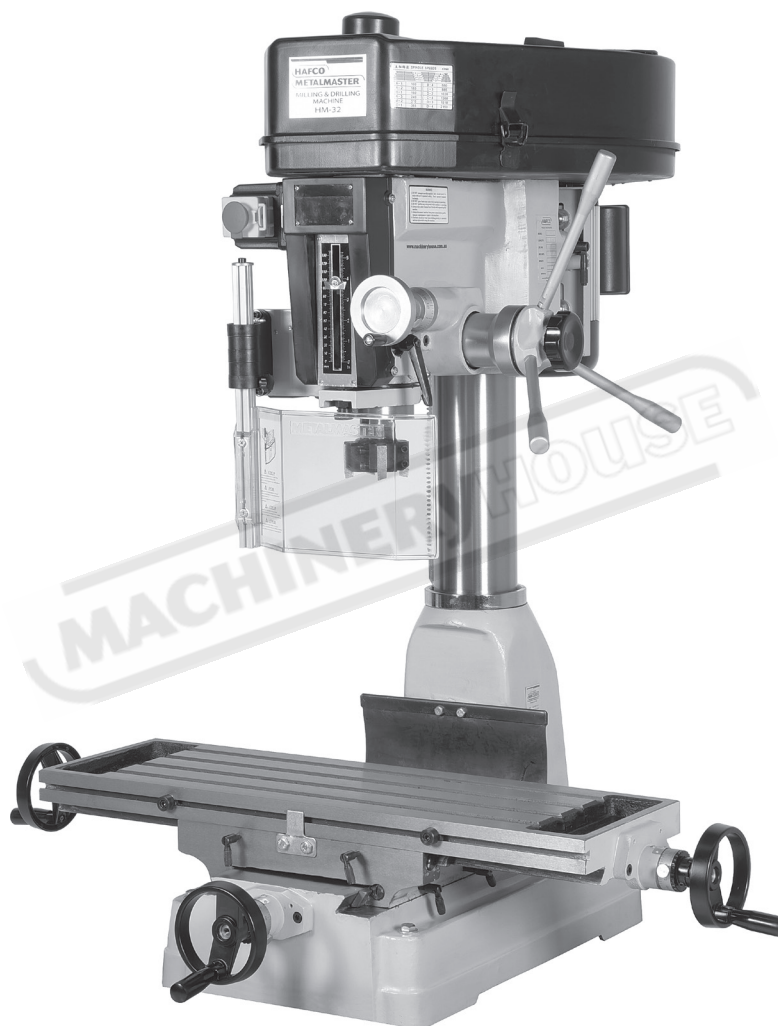

**Model.
HM-32**

Edition No :MD001

Date of Issue : 01/17

www.machineryhouse.com.au



OPERATION MANUAL

MACHINE DETAILS

MACHINE	MILL DRILL
MODEL NO.	HM-32
SERIAL NO.	
DATE OF MANF.	

Distributed by



www.machineryhouse.com.au

www.machineryhouse.co.nz

Note:

This manual is only for your reference. Owing to the continuous improvement of the machine, changes may be made at any time without obligation or notice. Please ensure the local voltage is the same as listed on the specification plate before operating this electric machine.



NOTE:

In order to see the type and model of the machine, please see the specification plate. Usually found on the back of the machine. See example (Fig.1)

HAFCO
PRODUCT SPECIFICATION

MODEL:

CAPACITY:

SER. NO.:

MFG DATE:

WEIGHT:

VOLTS:

MOTOR Kw:

www.machineryhouse.com.au
Made in China

Fig.1



OPERATION MANUAL

CONTENTS:

1. GENERAL MACHINE INFORMATION

1.1 Specifications.....	4
1.2 Standard Equipment.....	4
1.3 Identification.....	5
1.4 Electrical Controls.....	6
1.5 Accessories.....	6

2. SAFETY

2.1 Safety Requirements.....	7
2.2 Power Supply.....	10
2.3 Site Preparation.....	10
2.3 Lifting Instructions.....	11

3. SETUP

3.1 Mounting The Mill Drill On Optional Stand.....	11
3.2 Mounting To A Workbench.....	12
3.2 Leveling.....	12

4. OPERATION & TEST RUN

4.1 Test Run The Machine.....	13
4.2 Changing Spindle Speeds.....	14
4.3 Basic Controls.....	15

5. MAINTAINANCE

5.1 Troubleshooting.....	16
5.2 Lubrication.....	17
5.3 Optional Accessories.....	18

APPENDIX

A. Electrical Circuit Diagram.....	19
Spare Parts.....	20
Risk Assessment Sheets.....	25

OPERATION MANUAL

1.1. SPECIFICATIONS....

Table Size	820 x 240mm
Column Type	Ø 115mm
Spindle Taper	3MT
Longitudinal Travel (X-Axis)	540mm
Cross Travel (Y-Axis)	190mm
Vertical Travel (Z-Axis)	410mm
Type of Slides	Dovetail
Spindle to Table	455mm
Quill Travel / Diameter	130mm / 75mm
Throat Depth (max)	202mm
Tilting Head (Left~Right)	Fixed
Tilting Head (Front~Back))	Fixed
Drilling Capacity	31.5mm
End Mill Capacity	22mm
Face Mill Capacity	80mm
Power Feed~Longitudinal (X-Axis)	Optional
Table T-Slot	14mm
Work Table Load Capacity	50kg
Spindle Speeds (Steps/RPM)	12 (100~2150)
Motor Power	1.5kW / 2hp
Motor Voltage	240Volts
Overall Height	1100mm
Weight	295kgs

1.2. STANDARD EQUIPMENT

Drill Chuck & Arbour
 3MT ~ 2MT Drill Sleeve
 Face Cutter and Arbour
 3" Tilt Vice
 Safety Cutter Guard

1.3 IDENTIFICATION

Fig. 1

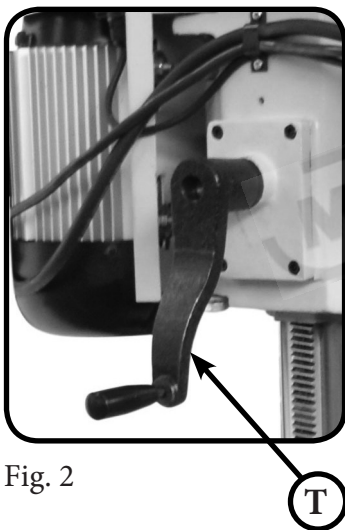
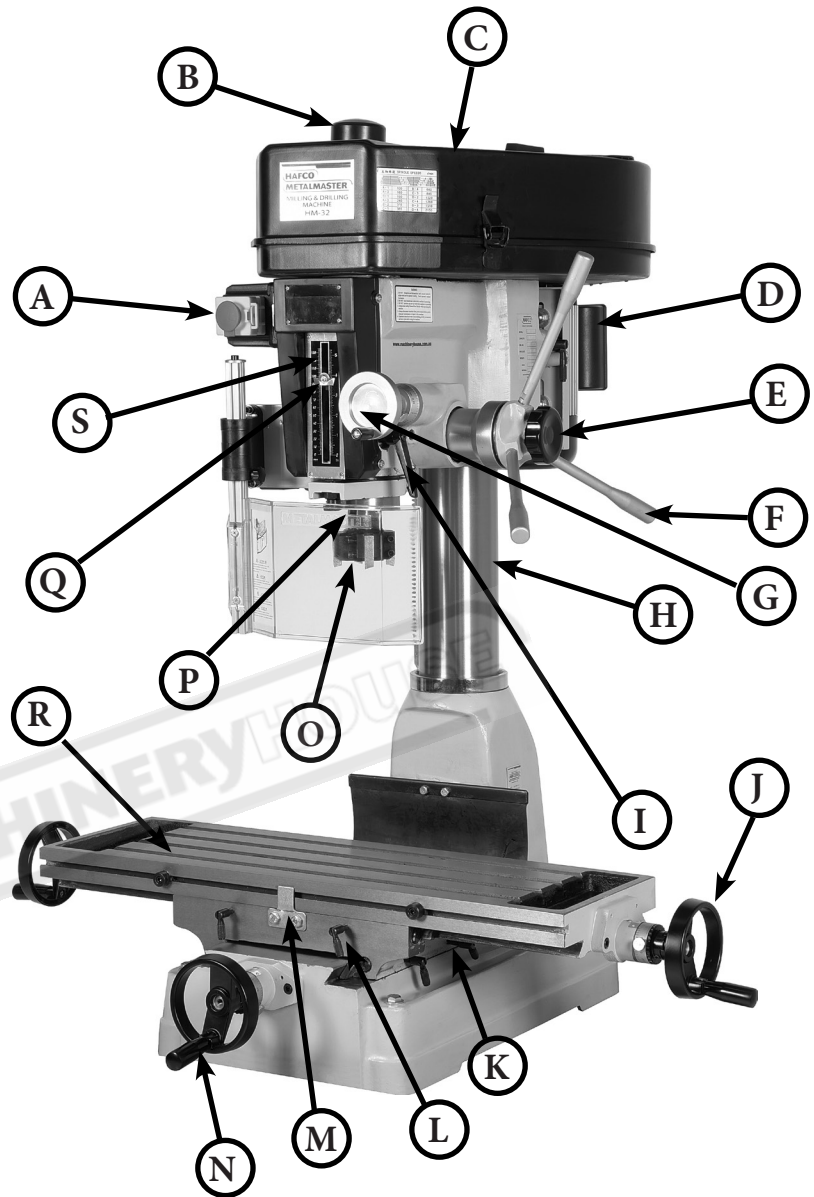
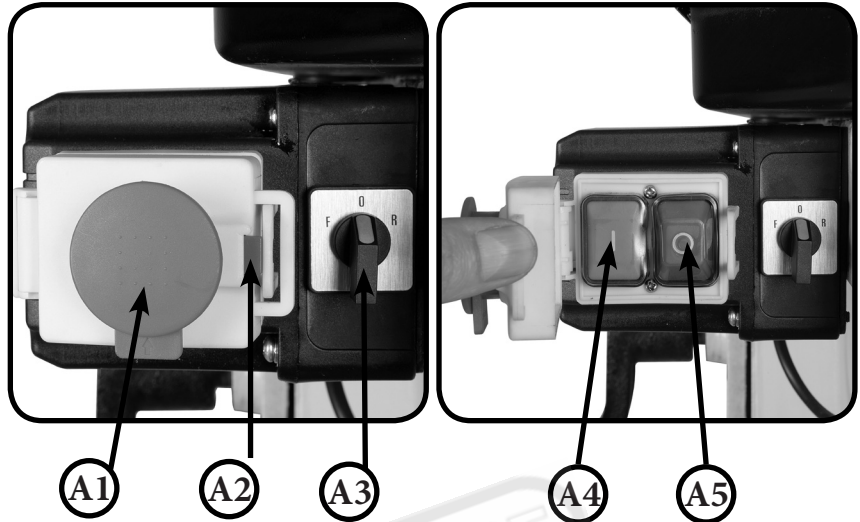

Fig. 2

- | | |
|----------------------------|---------------------------------------|
| A. ON/OFF Buttons | K. Cross Travel Lock |
| B. Drawbar & Cap | L. Longitudinal Travel Lock |
| C. Belt Cover | M. Table Stop |
| D. Motor | N. Cross Travel Handwheel |
| E. Fine Downfeed Lock Knob | O. Face Mill |
| F. Coarse Downfeed Lever | P. Spindle |
| G. Fine Downfeed Handwheel | Q. Depth Stop |
| H. Column | R. Table |
| I. Quill Lock Lever | S. Depth Scale |
| J. Longitudinal Handwheel | T. Headstock Elevation Crank (Fig. 2) |

1.4 ELECTRICAL CONTROLS

A1. Emergency Stop
A2. Emergency Stop Release
A3. Forward/Reverse Switch
A4. Start Button
A5. Stop Button



1.5 ACCESSORIES

1. Machine Vice
2. Face Mill and Arbour
3. Drill Chuck
4. Drill Chuck Key
5. Drill Drift
6. Hex Keys
7. 3mt - 2mt Drill Sleeve
8. Socket Spanner
9. Drill Chuck Arbour

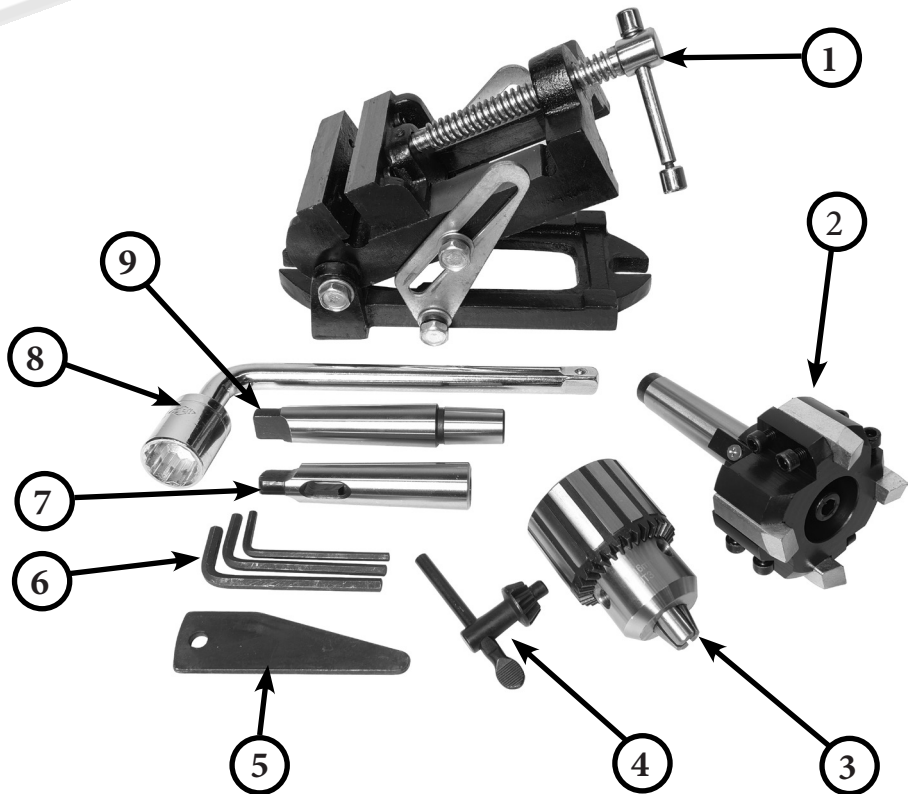

OPERATION MANUAL**2. SAFETY****2.1 SAFETY REQUIREMENTS**

OWNER'S MANUAL. Read and understand this owner's manual before using the machine.

TRAINED OPERATORS ONLY. Untrained operators have a higher risk of being hurt or killed. Only allow trained/supervised people to use this machine. When machine is not being used, disconnect power, remove switch keys, or lock-out machine to prevent unauthorized use—especially around children. Make workshop kid proof!

DANGEROUS ENVIRONMENTS. Do not use the machinery in areas that are wet, cluttered, or have poor lighting. Operating machinery in these areas greatly increases the risk of accidents and injury.

MENTAL ALERTNESS REQUIRED. Full mental alertness is required for safe operation of the machinery. Never operate under the influence of drugs or alcohol, when tired, or when distracted.

ELECTRICAL EQUIPMENT INJURY RISKS. You can be shocked, burned, or killed by touching live electrical components or improperly grounded machinery. To reduce this risk, only allow qualified service personnel to do electrical installation or repair work, and always disconnect power before accessing or exposing electrical equipment.

EYE PROTECTION. Always wear approved safety glasses or a face shield when operating or observing machinery to reduce the risk of eye injury or blindness from flying particles. Everyday eyeglasses are not approved safety glasses.

WEARING PROPER APPAREL. Do not wear clothing, or jewelry that can become entangled in moving parts. Always tie back or cover long hair. Wear non-slip footwear to avoid accidental slips.

HEARING PROTECTION. Always wear hearing protection when operating or observing loud machinery. Extended exposure to this noise without hearing protection can cause permanent hearing loss.

REMOVE ADJUSTING TOOLS. Tools left on machinery can become dangerous projectiles upon startup. Never leave drill chuck keys, wrenches, or any other tools on machine. Always make sure they are removed before starting!

USE CORRECT TOOL FOR THE JOB. Only use this machine for its intended purpose. Do not force it or an attachment to do a job for which it was not designed. Never make unapproved modifications. Modifying tools or using it not as it was intended may result in malfunction or mechanical failure that can lead to personal injury or death!

AWKWARD POSITIONS. Keep proper footing and balance at all times when operating the machine. Do not overreach! Avoid awkward hand positions that make workpiece control difficult or increase the risk of injury.

GUARDS & COVERS. Guards and covers reduce accidental contact with moving parts or flying debris. Make sure they are properly installed, undamaged, and working correctly.

2.1 SAFETY REQUIREMENTS Cont.



WARNING

FORCING MACHINERY. Do not force the machine. It will do the job safer and better at the rate for which it was designed.

NEVER STAND ON MACHINE. Serious injury may occur if machine is tipped or if the cutting tool is unintentionally contacted.

STABLE MACHINE. Unexpected movement during operation greatly increases risk of injury or loss of control. Before starting, verify the machine is stable and mobile base (if used) is locked.

USE RECOMMENDED ACCESSORIES. Consult this owner's manual or the manufacturer for recommended accessories. Using improper accessories will increase the risk of serious injury.

UNATTENDED OPERATION. To reduce the risk of accidental injury, turn machine OFF and ensure all moving parts are completely stopped before walking away. Never leave machine running while unattended.

CHILDREN & BYSTANDERS. Keep children and bystanders at a safe distance from the work area. Stop using the machine if they become a distraction.

MAINTAIN POWER CORDS. When disconnecting machines from power, grab and pull the plug and not the cord. Pulling the cord may damage the wires inside. Do not handle cord/plug with wet hands. Avoid cord damage by keeping it away from heated surfaces, high traffic areas, harsh chemicals, and wet/damp locations.

MAINTAIN WITH CARE. Follow all maintenance instructions and lubrication schedules to keep the machine in good working condition. Improperly maintained machine can malfunction and could cause serious personal injury.

CHECK DAMAGED PARTS. Regularly inspect the machine for any condition that may affect a safe operation. Immediately repair or replace damaged parts before operating the machine.

DISCONNECT POWER FIRST. Always disconnect the machine from the power supply before making adjustments, changing tooling, or servicing the machine. This prevents an injury risk from unintended startup or contact with live electrical components.

OPERATION MANUAL

2.1 SAFETY REQUIREMENTS Cont.

UNDERSTANDING CONTROLS. Make sure you understand the use and operation of all controls.

SAFETY ACCESSORIES. Always use a chip guard in addition to your safety glasses when milling to prevent bodily injury.

WORK HOLDING. Before starting the machine, be certain the workpiece has been properly clamped to the table. **NEVER** hold the workpiece by hand when using the mill.

CHUCK KEY SAFETY. Always remove your chuck key, drawbar wrench, and any service tools immediately after use.

CLEAN-UP. DO NOT Clear chips by hand. Use a brush, and never clear chips while the mill is turning.

CUTTING TOOL INSPECTION. Inspect drills and end mills for sharpness, chips, or cracks before each use. Replace dull, chipped, or cracked cutting tools immediately. Handle new cutting tools with care. Leading edges are very sharp and can cause lacerations.

SPINDLE SPEEDS. Select the spindle speed that is appropriate for the type of work and material. Allow the mill/drill to gain full speed before beginning a cut.

POWER DISRUPTION. In the event of a local power outage during use of the mill, turn OFF all switches to avoid possible sudden start up once power is restored.

SPINDLE DIRECTION CHANGES. Never reverse spindle direction when milling, boring, or facing a workpiece.

STOPPING SPINDLE. DO NOT stop the mill/drill using your hand against the chuck.

DISCONNECT POWER. Make sure the mill is turned off, disconnected from its power source, and all moving parts have come to a complete stop before starting any inspection, adjustment, or maintenance procedure.

TOOL HOLDING. Always use the proper tools for the material you are milling. Make sure they are held firmly in the proper tool holder for the job.



OPERATION MANUAL

2.2 POWER SUPPLY

Availability

Before installing the machine, consider the availability and proximity of the required power supply circuit. If an existing circuit does not meet the requirements for this machine, a new circuit must be installed. To minimize the risk of electrocution, fire, or equipment damage, installation work and electrical wiring must be done by an electrician or qualified service personnel in accordance with all applicable codes and standards.

Electrical Requirements

Nominal Voltage.....	240V
Cycle.....	50 Hz
Phase.....	Single-Phase
Power Supply Circuit.....	10Amps
Full Load Amps.....	8.8 Amps
Motor Speed.....	1400 RPM

Extension Leads

It is not recommend to use an extension cord with this machine. If you must use an extension cord, only use it if absolutely necessary and only on a temporary basis. Extension cords cause voltage drop, which may damage electrical components and shorten motor life. Voltage drop increases as the extension cord size gets longer and the gauge size gets smaller Any extension cord used with this machine must be approved. It is recommended that the machine be plugged directly into a power point

2.3 SITE PREPARATION

When selecting the site for the machine, consider the largest size of workpiece that will be processed through the machine and provide enough space around the machine for operating the machine safely. Consideration should be given to the installation of auxiliary equipment. Leave enough space around the machine to open or remove doors/covers as required for the maintenance and service as described in this manual.

It is recommended that the machine is anchored to the floor to prevent tipping or shifting. It also reduces vibration that may occur during operation, Use the holes in the bottom of the cabinets as guides for drilling holes in the floor and mount the stand.

The machine is best mounted on a optional stand bolted to the floor or concrete slab (HAFCO M135A) Masonry anchors with bolts are the best way to anchor machinery, because the anchors sit flush with the floor surface, making it easy to unbolt and move the machine later, if needed. (Fig. 3)

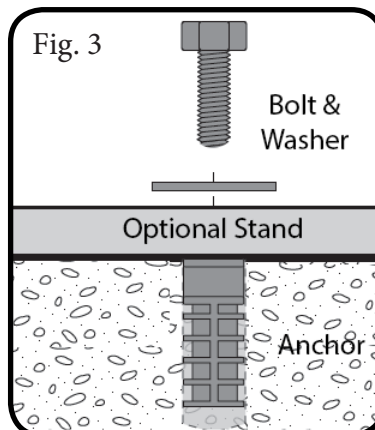

OPTIONAL STAND



OPERATION MANUAL

Z

Place the web lifting straps under the head of the machine, as shown in Fig. 4, then connect them to a forklift. Be sure that the straps connect to the forklift far enough apart that they are not putting pressure on the belt cover.

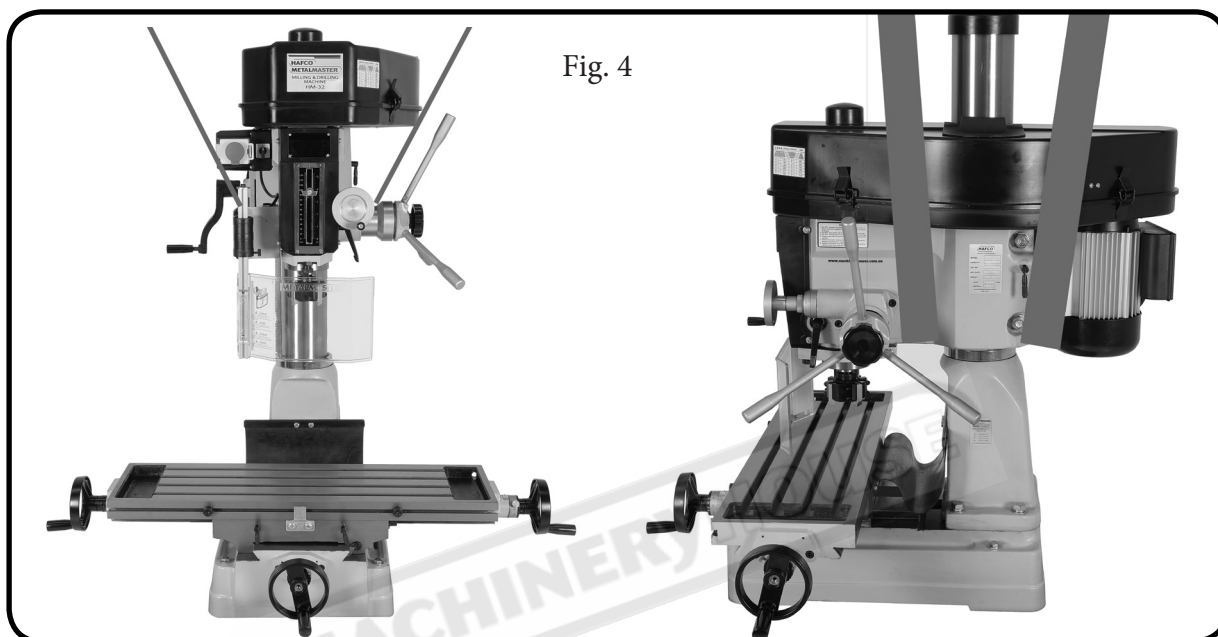

Fig. 4

Lift the machine and carefully place it onto the cabinet or workbench.

3. SETUP

3.1 MOUNTING THE MILL DRILL ON OPTIONAL STAND

Before you place your machine on the cabinet, it is recommended you consider the following options.

When mounting on the optional cabinet consider using Hafco M0015 machine mounts to make it easy for leveling and eliminates vibration.

Bolting the machine also to the floor prevents tipping or shifting and reduces vibration that may occur during operation, resulting in a machine that runs slightly quieter and feels more solid.

If the machine will be installed in a commercial or workplace setting, or if it is permanently connected (hardwired) to the power supply, then it should be anchored to the floor.



M0015

3.2 MOUNTING TO A WORKBENCH

If you are placing the machine on an existing workbench, it must be securely attached to the workbench.

The base of this machine has mounting holes that allow it to be fastened to a workbench or other mounting surface to prevent it from moving during operation and causing accidental injury or damage.

The strongest mounting option is where holes are drilled all the way through the workbench and bolts, washers, and hex nuts are used to secure the machine in place. (Fig. 6)

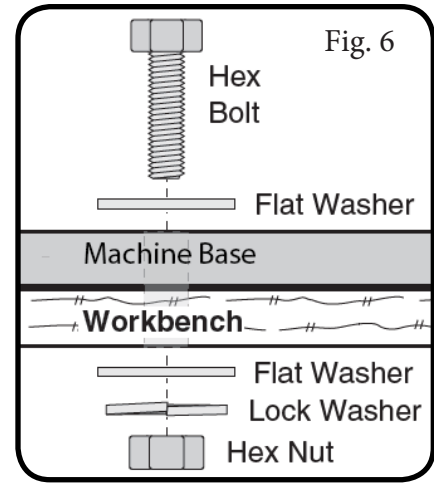

3.3 LEVELING

Whether you mount your machine to the cabinet stand or to an existing workbench, it must be leveled. If you mounted your machine to an existing workbench, use a precision level and metal shims as needed under the machine base to make sure the machine table is level from side-to-side and from front-to-back. If you mounted your machine to the cabinet, use a precision level on the table and adjust the cabinet's leveling bolts to make sure the machine table is level from side-to-side and from front-to-back. (Fig. 7)

If the machine is to be mounted to the cabinet and then mounted to the floor, and if the use of Hafco Machine Mounts M0015 are being used, use a precision level and adjust the machine mounts until the machine table is level.



Fig. 7



OPERATION MANUAL

4. OPERATION & TEST RUN

Once the assembly is complete, test run your machine to make sure it runs properly and is ready for regular operation. The test run consists of checking the following:

- 1) The motor powers up and runs in the correct direction
- 2) the stop button safety feature works correctly.

If, during the test run, you cannot easily locate the source of an unusual noise or vibration, stop using the machine immediately, then review Troubleshooting on Page 41.

4.1 TEST RUN THE MACHINE

1. Make sure you understand the safety instructions at the beginning of the manual and that the machine is set up properly.
2. Make sure all tools and objects used during setup are cleared away from the machine.
3. Connect the machine to the power source.
4. Push the EMERGENCY STOP button in, then press the release tab (see Fig. 7) so that the yellow door pops open. When the EMERGENCY STOP button yellow door pops open, the On/OFF switches are exposed. The machine is now ready for operation.
5. Verify that the machine is operating correctly by switching the Forward/Reverse switch (Fig. 8) to the right to the forward position and press the green ON button. —When operating correctly, the machine will run smoothly with little or no vibration or rubbing noises. Investigate any strange or unusual noises or vibrations before operating the machine further. Always turn the machine off, by pressing the red button that will close the yellow door and conceal the ON/OFF buttons. Then disconnect the machine from power and investigate or correct any potential problems.
6. Press the large red STOP button to stop the machine. Allow the spindle to stop rotating before proceeding.
7. Repeat Step 5 with the Forward/Reverse switch to the left to select reverse then press the green On button. The spindle should now rotate in the opposite direction.
8. Press the large red EMERGENCY STOP button to stop the machine. Allow the spindle to stop rotating before proceeding.
9. With the yellow door closed and the ON/OFF button concealed, switch the forward reverse switch to the left and to the right.

If the machine does not start, the EMERGENCY STOP button safety feature is working correctly. The Test Run is complete

Fig. 7

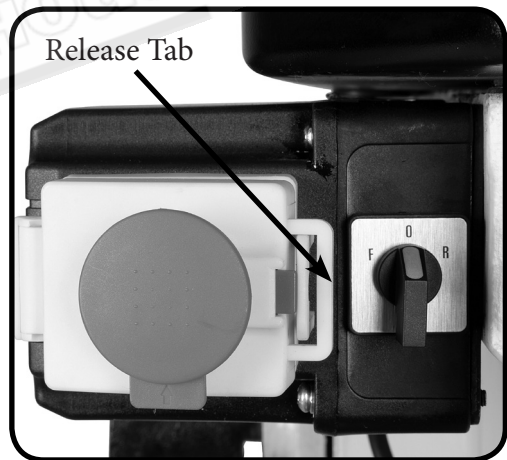
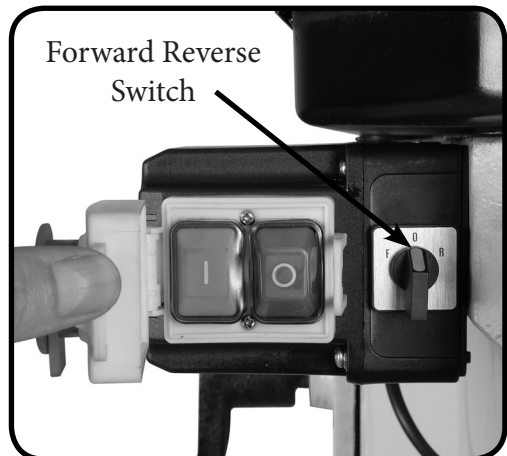

Fig. 8





OPERATION MANUAL

4.2 CHANGING SPINDLE SPEEDS

The Model HM-32 is capable of twelve different speed settings. Different types of cuts and materials require varying speeds. For the correct speed refer to publication such as Hafco L341 Fitting and Machining

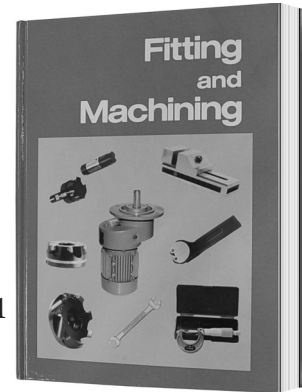

Order Code L341

To change spindle speeds:

1. DISCONNECT MACHINE FROM POWER!
2. Loosen the motor locking lever. Pull the motor inward to move the rear pulley toward the spindle, then re-tighten the locking lever. (Fig. 9)



Fig. 9 Motor Locking Lever

3. Open the belt cover, then loosen the two idler cap screws (Fig. 10) that hold the idler pulley in place so it can move freely.



Fig. 10 Idler Screws

4. With the center and rear pulleys loose, move the V-belts to the corresponding position for the desired speed (see chart below Fig. 11).
5. Loosen the motor locking lever and allow the spring to tighten the rear V-Belt, then re-tighten the motor locking lever.
6. Tighten the cap screws holding the idler pulley in place, then close and latch the belt cover.

SPINDLE SPEEDS			
	4		A
	3		B
	2		C
	1		D
A1	100	B4	660
A2	160	C3	885
B1	190	D2	1020
A3	240	C4	1260
B2	310	D3	1510
C1	365	D4	2150

Fig. 11

4.3 BASIC CONTROLS

Listed below are the machines basic controls and their description. The operator should be familiar with these items and the terminology.

Depth Stop: When set this stops the spindle travel at a predetermined depth. This is set by turning the knurled knob at the bottom of the scale.

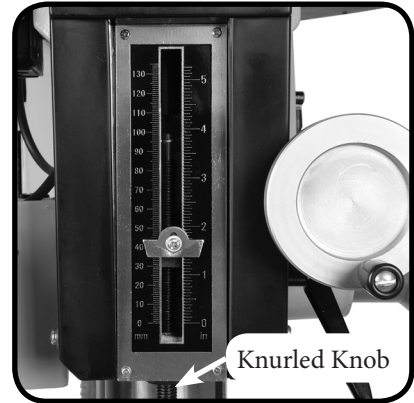

Knurled Knob

Fine Downfeed Handwheel: Provides manual hand fine feed control of the vertical spindle travel.

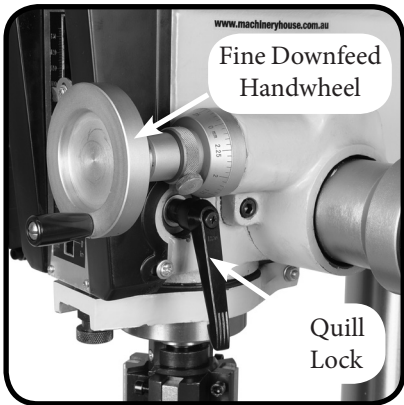

Fine Downfeed Handwheel

Quill Lock

Quill Lock: Locks the quill in position and increases rigidity

Locking Knob: Engages/disengages the fine feed handwheel.

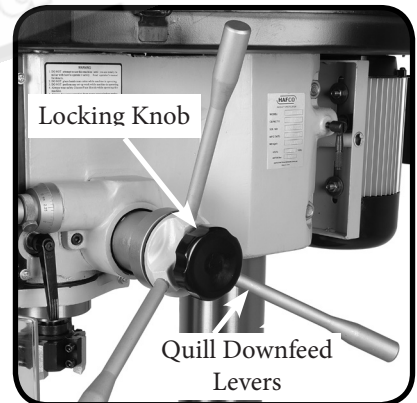

Locking Knob

Quill Downfeed Levers

Quill Downfeed Levers: Provide coarse control over vertical spindle travel.

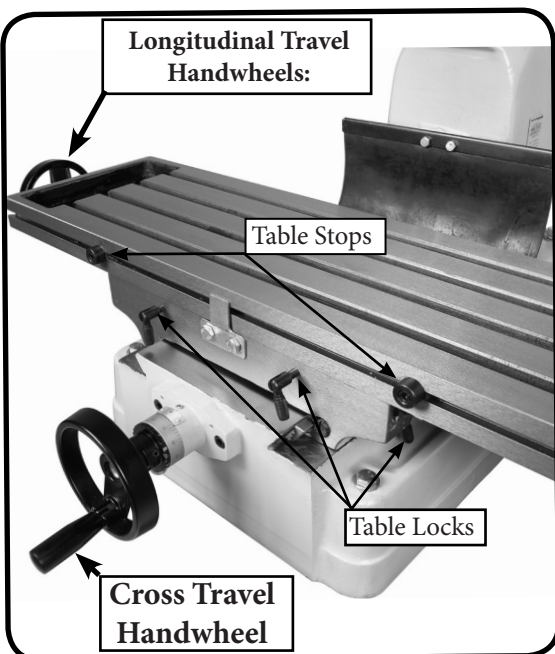

Longitudinal Travel Handwheels:

Table Stops

Table Locks

Cross Travel Handwheel

Longitudinal Travel Handwheels: Control longitudinal (X-Axis) travel of the table.

Cross Travel Handwheel: Controls cross (Y-Axis) travel of the table.

Table Locks: Lock the table in position along their respective axes.

Travel Stops: Limit longitudinal table travel.

OPERATION MANUAL

5. MAINTAINANCE

5.1 TROUBLESHOOTING

SYMPTOMS	POSSIBLE CAUSE	POSSIBLE SOLUTION
Machine does not start	<ol style="list-style-type: none"> 1. Wall fuse or circuit breaker has been tripped 2. Plug faulty or wired incorrectly 3. Motor wired incorrectly 4. Machine power switch faulty 5. Faulty motor 6. Micro switch open 	<ol style="list-style-type: none"> 1. Reset circuit breaker or change fuse 2. Ensure plug is not damaged and is wired correctly 3. Ensure motor is wired correctly 4. Test and replace if faulty 5. Test and replace if faulty 6. Check the micro switch on the belt guard is closed.
Machine stalls or is over-loaded	<ol style="list-style-type: none"> 1. Feed rate too fast or cutting speed to slow 2. Wrong cutter type 3. Motor is overheated 4. Motor bearings are faulty 	<ol style="list-style-type: none"> 1. Adjust feed rate or cutting speed 2. Use the correct cutter for the job 3. Clean motor, let cool and reduce workload 4. Test by rotating the shaft. Replace bearings if faulty.
Machine has vibrations or noisy operation	<ol style="list-style-type: none"> 1. Motor or machine component is loose 2. Excessive depth of cut 3. Cutter tool loose or dull 4. Quill is over extended. 	<ol style="list-style-type: none"> 1. Inspect for loose bolts , tighten or replace 2. Decrease the depth of cut. 3. Reinsert the tool or replace if dull. 4. Retract the quill and lower the head

OPERATION MANUAL

5.2 LUBRICATION

Points requiring periodic lubrication are:

A. Column. A light film of oil (ISO VG-68) will smooth action and prevent rust and corrosion.

B. Column Rack. Lubricate every 90 days with a general purpose industrial NLGI 2 grease

C. Quill. A light coating of oil (Mobil Vactra 2) will ensure smooth movement.

D. Quill Rack. Lubricate every 90 days with a general purpose industrial and NLGI 2 grease

E. Table Leadscrews. Lubricate once each week with several drops of Mobil Vactra 2 or equivalent way oil.

F. Ball Oilers. Wipe the outer surface of the ball fitting with a clean cloth to remove contaminants. Press the ball of the fitting with the tip of the oiler. Press a few drops of Mobil Vactra 2 or equivalent way oil into the ball fitting, then clean up any residue with a cloth.

G. Ways. Periodically lubricate the ways with Mobil Vactra 2 or way oil.

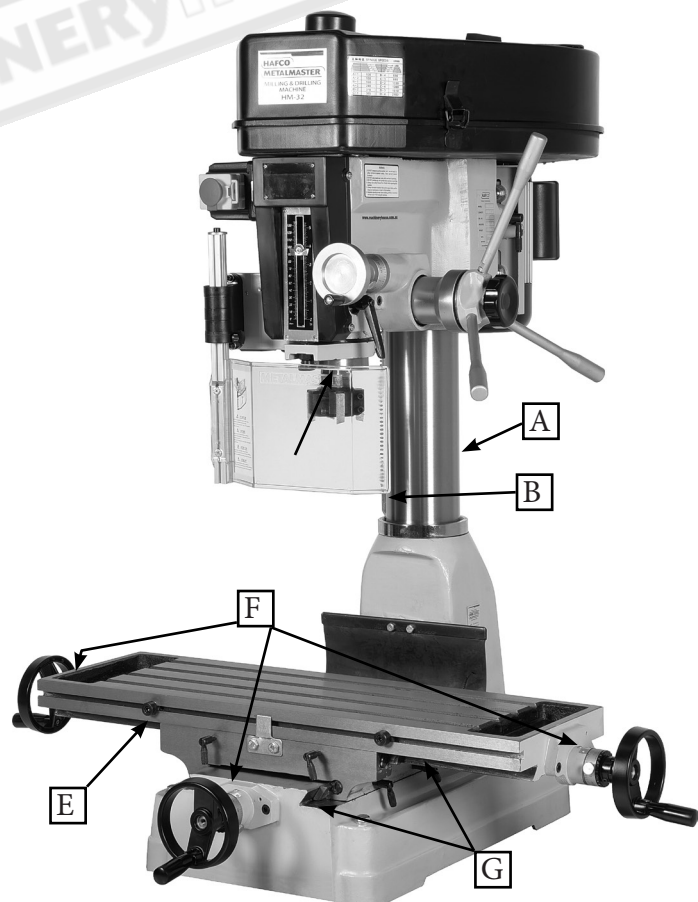
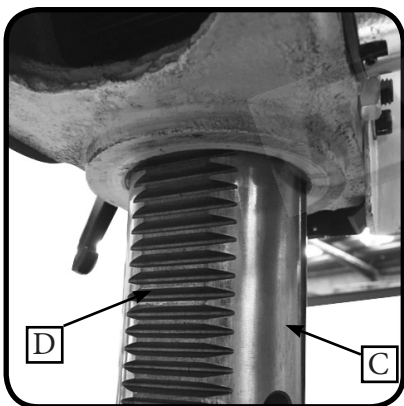

OPERATION MANUAL

5.3 OPTIONAL ACCESSORIES

The HM-32 Mill Drill is supplied with some basic tooling. Below is a list of quality tooling that may be needed to enhance the scope of the machine.

TOOLMASTER C922B—3MT Chuck & Collet Set

An affordable quick change collet system with ultra precision. These spring collets are hardened and ground to exacting tolerances and offer incredible holding power. This set includes an 3MT x ER32 collet chuck, spanner wrench, plastic carrying case and collets sized 7-6mm, 8-7mm, 10-9mm, 13-12mm, 16-15mm and 20-19mm. These collets can also be used for imperial sizes. Drawbar size 1/2" whitworth

Order Code C933B



HAFCO C0965 —14MM 52-PC . Clamping Kit

This clamping kit includes 24 studs, six step block pairs, six T-nuts, six flange nuts, four coupling nuts, and six end hold-downs. The rack is slotted so it can be mounted.

Order Code C0965

ALIGN M230—Power Feed for Mill Drills

If you want to get the most out of your mill drill you really need a power feed. This power feed unit comes with everything required to start milling with exact control. Comes supplied with easy to assemble mounting bracket, drive belt and pulley, and auto-stop limit switch with movable stop.

Order Code M230



Always use
quality
Alcock
Cutters

TM M529—Carbide Insert Face Mill

This 50mm Face Mill accepts four carbide inserts (not included). Comes with an 3MT arbor.

Uses Inserts TPKN1603 (L0661)

Order Code M529





OPERATION MANUAL

A. ELECTRICAL DIAGRAM

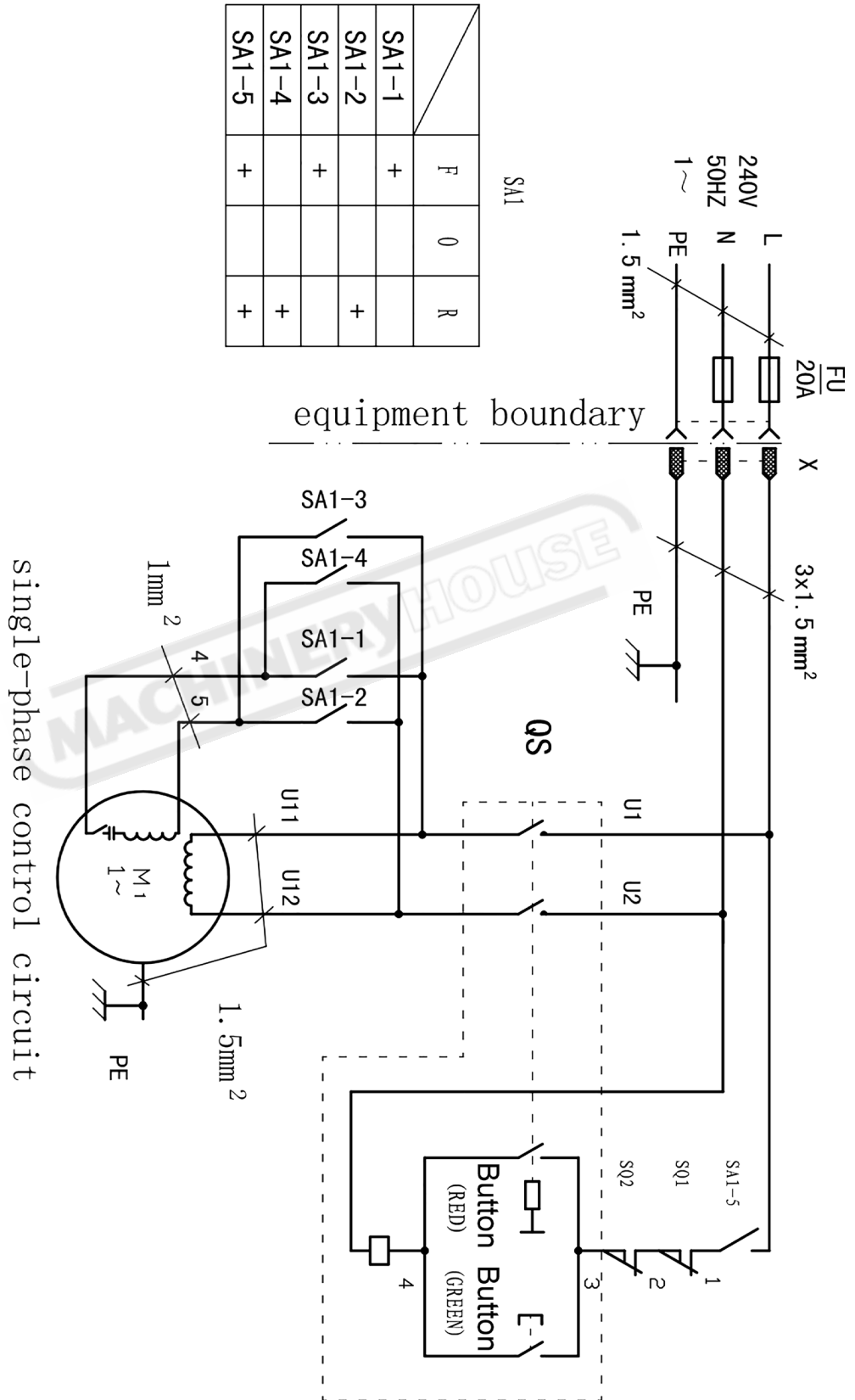

SPARE PARTS SECTION

The following section covers the spare parts diagrams and lists that were current at the time this manual was originally printed. Due to continuous improvements of the machine, changes may be made at any time without notification.

HOW TO ORDER SPARE PARTS

1. Have your machines **model number, serial number & date of manufacture** on hand, these can be found on the specification plate mounted on the machine
2. A scanned copy of your parts list/diagram with required spare part/s identified
3. Go to www.machineryhouse.com.au/contactus and fill out the enquiry form attaching a copy of scanned parts list.

CONTENTS

B.HeadBodyPartsList.....	21
C. TableColumnList.....	23



OPERATION MANUAL

B. HEAD BODY PARTS LIST

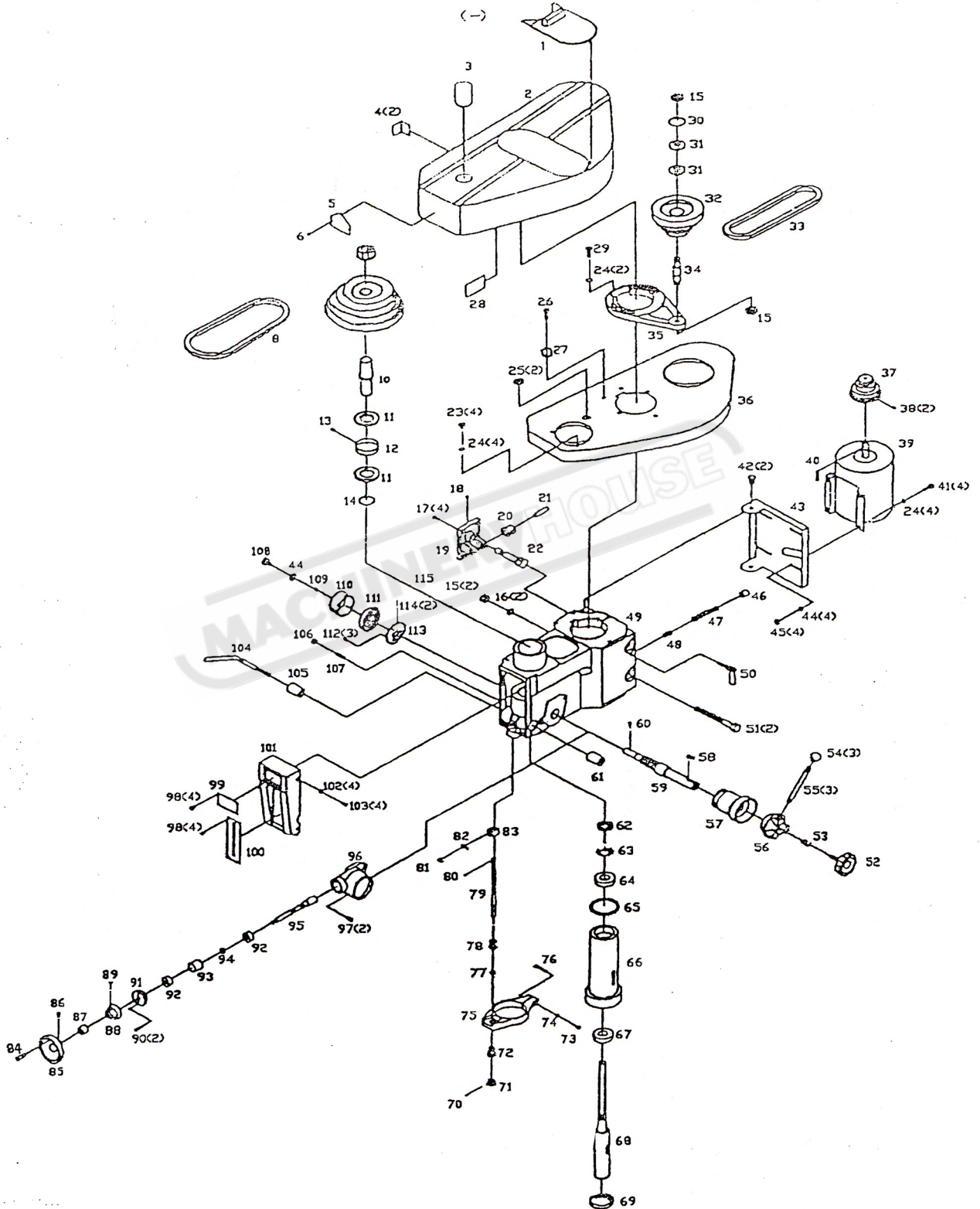

OPERATION MANUAL

B. HEAD BODY PARTS LIST

NO.	NAME	NO.	NAME	NO.	NAME
1	cover board	39	motor	77	nut
2	up cover	40	key	78	fixed nut
3	round	41	bolt	79	adjustable rod
4	jaw	42	bolt	80	pin
5	trademark	43	motor rack	81	screw
6	rivet	44	washer	82	referral-board
7	nut	45	nut	83	stop lump
8	V-belt	46	balata jacketing	84	turn handle
9	spindle ring	47	tension pin	85	small hand wheel
10	splined sleeve	48	spring	86	screw
11	ball bearing	49	spindle box	87	adapter sleeve
12	separating ring	50	tight handle	88	graduation plate
13	screw	51	bolt	89	screw
14	retaining ring	52	big ripple handle	90	bolt
15	nut	53	spring	91	end lid
16	washer	54	handle ball	92	ball bearing
17	screw	55	handle rod	93	separating ring
18	oil cup	56	handle body	94	retaining ring
19	bracket	57	turbine	95	feed worm
20	gear	58	key	96	feed inst. support
21	shaft	59	gear shaft	97	bolt
22	worm	60	screw	98	screw
23	bolt	61	fixed collar thread	99	nameplate
24	washer	62	nut	100	scale
25	separating ring	63	washer	101	front cover board
26	screw	64	ball bearing	102	washer
27	wire californium	65	retaining	103	screw
28	warning board	66	sleeve	104	handle rod
29	bolt	67	ball bearing	105	fixed tight collar
30	retaining ring	68	spindle	106	nut
31	ball bearing	69	ball bearing lid	107	screw
32	middle pulley	70	pin	108	small ripple handle
33	V-belt	71	knob	109	washer
34	middle pulley shaft	72	locating sleeve	110	spring cap
35	pulley support	73	nut	111	spring plate
36	down cover	74	washer	112	screw
37	motor pulley	75	feed support	113	shaft sleeve
38	screw	76	bolt	114	pin



OPERATION MANUAL

C. TABLE COLUMN PARTS LIST

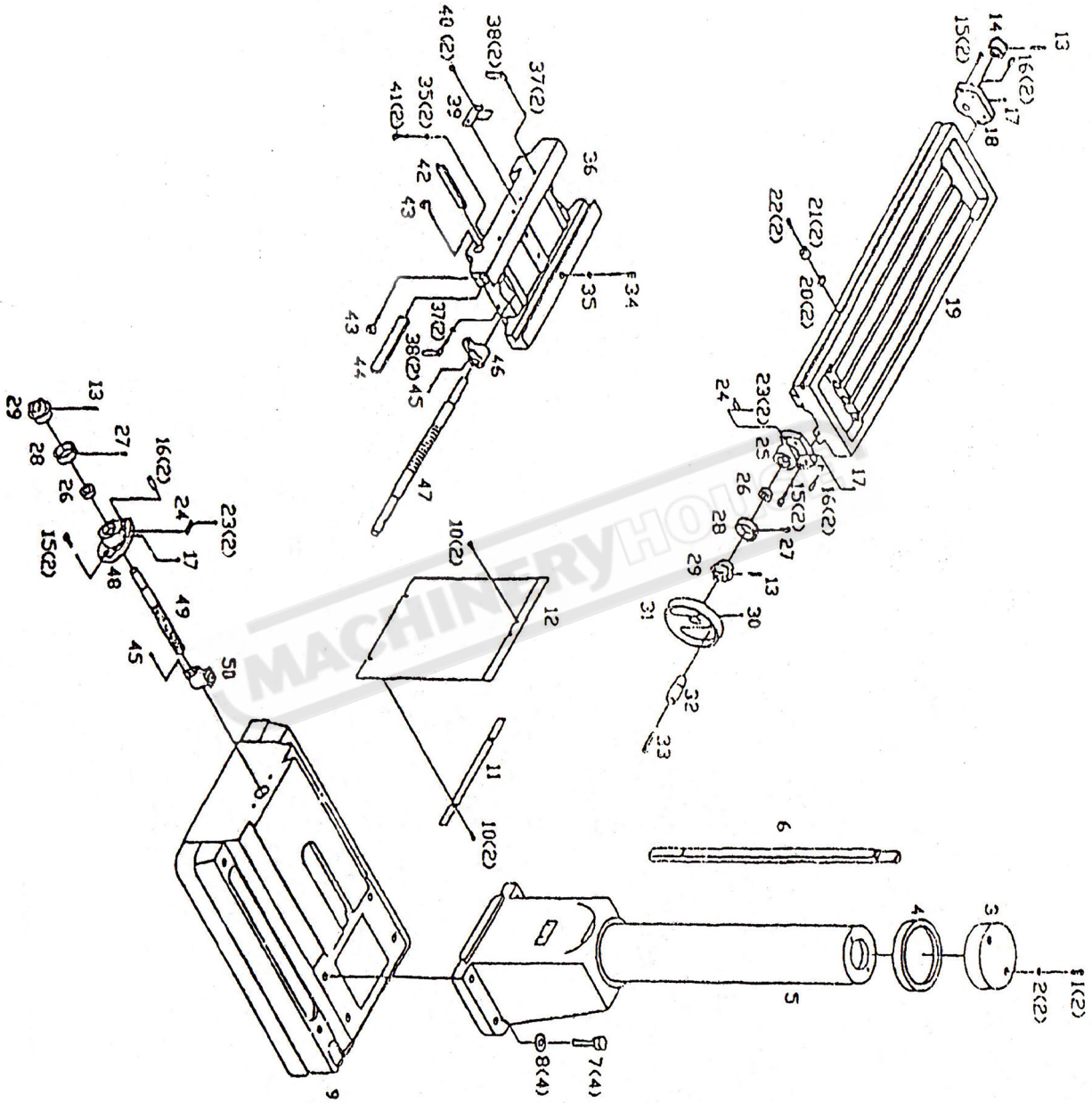

OPERATION MANUAL

C. TABLE COLUMN PARTS LIST

NO.	NAME	NO.	NAME
1	Screw	26	Ball Bearing
2	washer	27	Screw
3	Column Lid	28	Graduatiot Plate
4	Link	29	Dial Clutch
5	Column	30	screw
6	Rack	31	Hand Wheel
7	Bolt	32	Turn Handle
8	Washer	33	Screw
9	Base	34	Screw
10	Bolt	35	Washer
11	Protect Board Slice	36	Slip Saddle
12	Protect Board	37	Steel Ball
13	Pin	38	Lock Handle
14	Left Diai Clutch	39	Stop Lump
15	Screw	40	Bolt
16	Pin	41	Screw
17	Oil Cup	42	Gib Srrip
18	Left Support	43	Gib Srrip Screw
19	Table	44	Gib Srrip
20	Ladder-Shaped Nud	45	Screw
21	Stop Lump	46	Guide Screw Nut
22	Screw	47	Guide Screw
23	Rivew	48	Guide Screw Support
24	Zero Site Board	49	Guide Screw
25	Right Support	50	Guide Screw Nut



WARNING

General Machinery Safety Instructions

Machinery House
requires you to read this entire Manual before using this machine.

- 1. Read the entire Manual before starting machinery.** Machinery may cause serious injury if not correctly used.
- 2. Always use correct hearing protection when operating machinery.** Machinery noise may cause permanent hearing damage.
- 3. Machinery must never be used when tired, or under the influence of drugs or alcohol.** When running machinery you must be alert at all times.
- 4. Wear correct Clothing.** At all times remove all loose clothing, necklaces, rings, jewelry, etc. Long hair must be contained in a hair net. Non-slip protective footwear must be worn.
- 5. Always wear correct respirators around fumes or dust when operating machinery.** Machinery fumes & dust can cause serious respiratory illness. Dust extractors must be used where applicable.
- 6. Always wear correct safety glasses.** When machining you must use the correct eye protection to prevent injuring your eyes.
- 7. Keep work clean and make sure you have good lighting.** Cluttered and dark shadows may cause accidents.
- 8. Personnel must be properly trained or well supervised when operating machinery.** Make sure you have clear and safe understanding of the machine you are operating.
- 9. Keep children and visitors away.** Make sure children and visitors are at a safe distance for you work area.
- 10. Keep your workshop childproof.** Use padlocks, Turn off master power switches and remove start switch keys.
- 11. Never leave machine unattended.** Turn power off and wait till machine has come to a complete stop before leaving the machine unattended.
- 12. Make a safe working environment.** Do not use machine in a damp, wet area, or where flammable or noxious fumes may exist.
- 13. Disconnect main power before service machine.** Make sure power switch is in the off position before re-connecting.
- 14. Use correct amperage extension cords.** Undersized extension cords overheat and lose power. Replace extension cords if they become damaged.
- 15. Keep machine well maintained.** Keep blades sharp and clean for best and safest performance. Follow instructions when lubricating and changing accessories.
- 16. Keep machine well guarded.** Make sure guards on machine are in place and are all working correctly.
- 17. Do not overreach.** Keep proper footing and balance at all times.
- 18. Secure workpiece.** Use clamps or a vice to hold the workpiece where practical. Keeping the workpiece secure will free up your hand to operate the machine and will protect hand from injury.
- 19. Check machine over before operating.** Check machine for damaged parts, loose bolts, Keys and wrenches left on machine and any other conditions that may effect the machines operation. Repair and replace damaged parts.
- 20. Use recommended accessories.** Refer to instruction manual or ask correct service officer when using accessories. The use of improper accessories may cause the risk of injury.
- 21. Do not force machinery.** Work at the speed and capacity at which the machine or accessory was designed.
- 22. Use correct lifting practice.** Always use the correct lifting methods when using machinery. Incorrect lifting methods can cause serious injury.
- 23. Lock mobile bases.** Make sure any mobile bases are locked before using machine.
- 24. Allergic reactions.** Certain metal shavings and cutting fluids may cause an allergic reaction in people and animals, especially when cutting as the fumes can be inhaled. Make sure you know what type of metal and cutting fluid you will be exposed to and how to avoid contamination.
- 25. Call for help.** If at any time you experience difficulties, stop the machine and call you nearest branch service department for help.



WARNING

Lathe-Mill-Drill Safety Instructions

Machinery House
requires you to read this entire Manual before using this machine.

- 1. Maintenance.** Make sure the Lathe-Mill-Drill is turned off and disconnect from the main power supply and make sure all moving parts have come to a complete stop before any inspection, adjustment or maintenance is carried out.
- 2. Lathe-Mill-Drill Mill Drill Condition.** Lathe-Mill-Drill must be maintained for a proper working condition. Never operate a Lathe-Mill-Drill that has damaged or worn parts. Scheduled routine maintenance should be performed on a scheduled basis.
- 3. Leaving a Lathe-Mill-Drill Unattended.** Always shut the Lathe-Mill-Drill off and make sure all moving parts have come to a complete stop before leaving the Lathe-Mill-Drill. An unsupervised running Lathe-Mill-Drill can cause serious injury.
- 4. Avoiding Entanglement.** Remove loose clothing, belts, or jewelry items. Tie up long hair and use the correct hair nets to avoid any entanglement with moving parts.
- 5. Chuck key safety.** Never let go of a chuck key while still in the chuck to prevent leaving the chuck key in the chuck. Chuck keys left in the chuck can cause serious injury.
- 6. Understand the machines controls.** Make sure you understand the use and operation of all controls.
- 7. Tooling selection.** Always use the correct cutting tool for the job you are turning. Make sure it is sharp and held firmly in the tool post. Adjust the toolpost to provide proper support for the tool you will be using.
- 8. Tooling selection & holding.** Always use the correct cutting tool for the job you are milling. Make sure it is sharp and held firmly in place.
- 9. Cutting Tool inspection.** Inspect Drill and end mills for sharpness, chips, or cracks before use. Replace any cutting tools immediately if dull, chipped or cracked. Handle new cutting tools with care. Cutting edges are very sharp and can cause lacerations.
- 10. Reversing the spindle.** Make sure the spindle has come to a complete stop before changing the direction of the spindle. Do not slow or stop the spindle by using your hand.
- 11. Stopping the spindle.** Do not slow or stop the spindle by using your hand.
- 12. Mounting the workpiece.** Make sure the workpiece is properly mounted and secure before turning on the Lathe-Mill-Drill. A loose workpiece can be thrown across the room and cause serious injury to you or a bystander.
- 13. Workpiece clearance.** Rotate the workpiece by hand to check for clearance with the tool post, compound slide and carriage before turning the Lathe-Mill-Drill on.
- 14. Changing speeds and Reversing.** Turn the Lathe-Mill-Drill off and make sure the Lathe-Mill-Drill has come to a complete stop before changing speeds or reversing the spindle. Do not slow or stop the Lathe-Mill-Drill chuck by using your hand.
- 15. Speed selection.** Select the appropriate speed for the type of work, material, and tool bit. Allow the Lathe-Mill-Drill to reach full speed before beginning a cut.
- 16. Clearing chips.** Always use a brush to clear chips. Never clear chips when the Lathe-Mill-Drill is running.
- 17. Power outage.** In the event of a power failure during use of the Lathe-Mill-Drill, turn off all switches to avoid possible sudden start up once power is restored.
- 18. Clean work area.** Keep the area around the Lathe-Mill-Drill clean from oil, tools and chips.
- 19. Call for help.** If at any time you experience difficulties, stop the machine and call your nearest branch service department for help.

PLANT SAFETY PROGRAM

NEW MACHINERY HAZARD IDENTIFICATION, ASSESSMENT & CONTROL

Lathe Mill Drill (3 in 1)

Developed in Co-operation Between A.W.I.S.A and Australia Chamber of Manufactures
This program is based upon the Safe Work Australia, Code of Practice - Managing Risks of Plant in the Workplace (WHSA 2011 No10)

Item No.	Hazard Identification	Hazard Assessment	Risk Control Strategies <small>(Recommended for Purchase / Buyer / User)</small>
A	ENTANGLEMENT	HIGH	Eliminate, avoid loose clothing / Long hair etc.
C	CUTTING, STABBING, PUNCTURING	MEDIUM	Isolate power to machine prior to any checks or maintenance. Do not open or clean inside until the machine has completely stopped.
D	SHEARING	MEDIUM	Make sure all guards are secured shut when machine is on. Isolate power to machine prior to any checks or maintenance.
F	STRIKING	MEDIUM	Ensure workpiece is secured in chuck and tooling is locked tight in toolpost. Always wear safety glasses. Do not leave chuck key in chuck. Remove all loose objects around moving parts.
H	ELECTRICAL	MEDIUM	All electrical enclosures should only be opened with a tool that is not to be kept with the machine.
N	HIGH - TEMPERATURE	LOW	Wear appropriate protective clothing to prevent hot swarf.
O	OTHER HAZARDS, NOISE.	LOW	Wear hearing protection as required.
Plant Safety Program to be read in conjunction with manufactures instructions			



www.machineryhouse.com.au



www.machineryhouse.co.nz

Authorised and signed by:
Safety officer:



Manager:



Revised Date: 12th March 2012